

SMART GREYWATER SYSTEM

Description

The Smart Greywater System collects greywater from a house or building and supplies filtered greywater to the landscape drip irrigation system. A complete solution for the water-wise landscape, the system can save tens of thousands of gallons a year! The Smart Greywater System is easy to install and is ideal for renovation or new construction projects.

Applications

- Residential
- Light commercial
- Large irrigation systems

Features

- **Proven Track Record:** 10 years of R & D with hundreds of successful installations
- **Plug & Play Installation:** Greywater Manifold is factory built. Simply connect water, power, plug in the controller and you're ready to go!
- **Seamless Irrigation Integration:** Operates the same as a traditional irrigation system and is compatible with standard irrigation systems equipment
- **Smart Controller Compatible:** Works with *all* irrigation controllers, including smart controllers
- **Rainwater Ready:** Can incorporate another water source like rainwater or well water. Ask us more.
- **Low Maintenance Requirements:** Only once a year maintenance visit required!
- **Fully Automated Functionality:** No user involvement is required for system operation
- **Clog-Free Filtration:** Greywater filter is automatically cleaned to reduce maintenance
- **Complete Water Monitoring:** Keep track of the system water savings and irrigation flow rates
- **Advanced System Diagnostics/Alarms:** Receive system performance notifications on the Greywater Controller
- **California Code Ready:** Fully compliant with California Plumbing Code Chapter 16
- **Advanced Monitoring: (Optional)** Upgrade to see water savings on an internet dashboard in real time

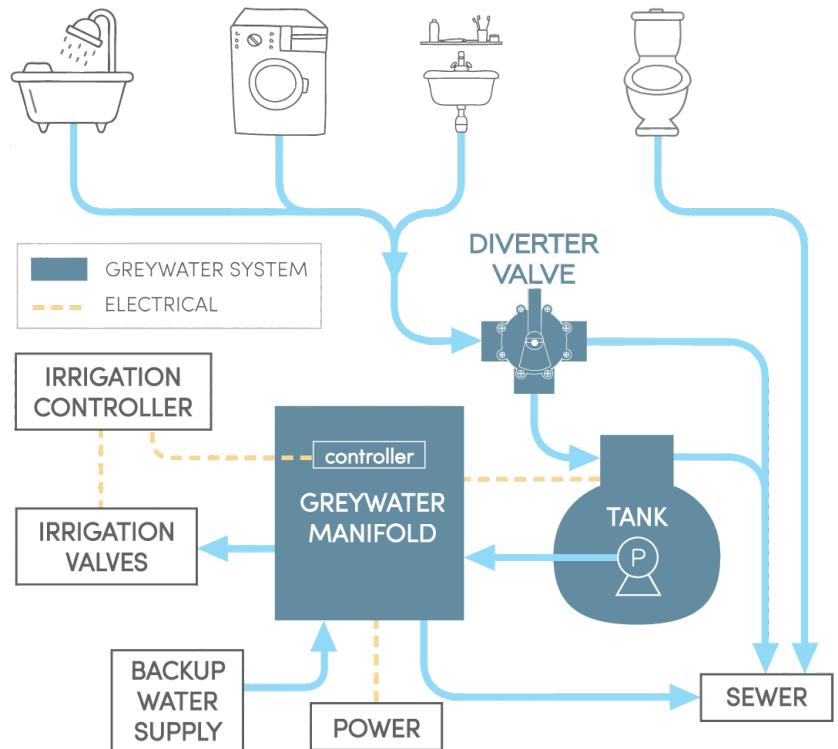

How It Works

1 Greywater Collection

Greywater from showers, laundry and bathroom sinks drain to a 3-way diverter valve located in an underground valve basin. The diverter valve drains to the Greywater Tank, or bypasses the tank and sends greywater to the sewer. The diverter valve is fitted with an automatic actuator that is operated by a switch on the Greywater Controller.

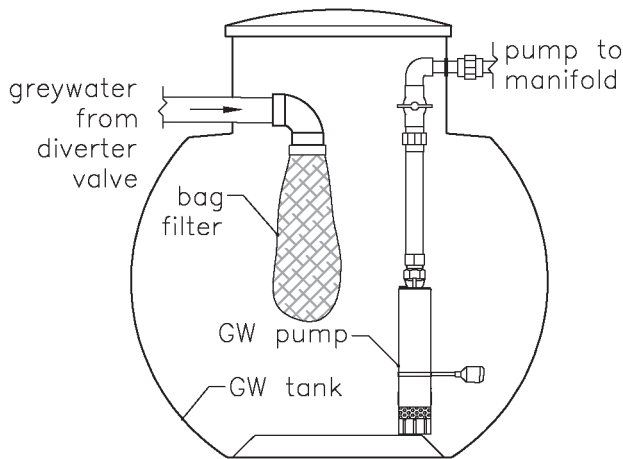
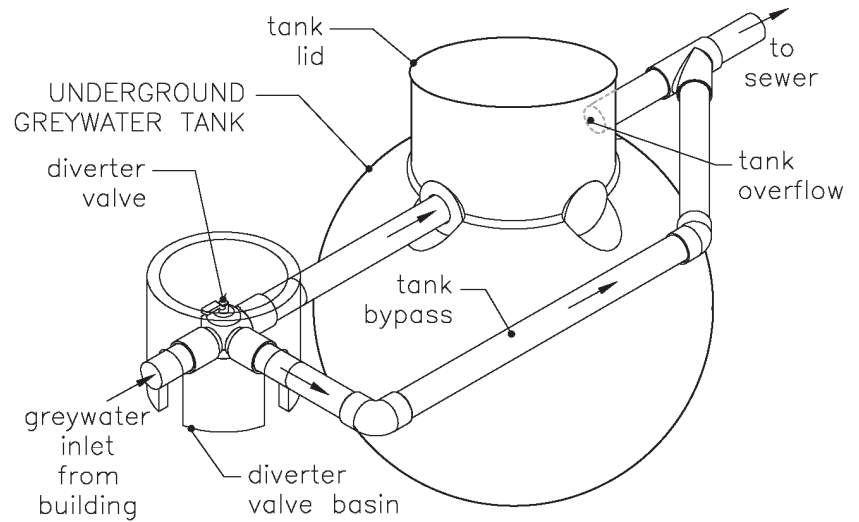

2 Greywater Tank

Greywater is temporarily stored in an underground tank totaling 250 gallons. Greywater entering the tank is filtered through a coarse 1200-micron bag filter. A pump in the tank sends the greywater to the Greywater Manifold.

3 Greywater Manifold

Greywater is pumped to the Manifold and passes through an additional 100 micron filter before being supplied to the irrigation system. Backup water is automatically supplied to the irrigation system if no greywater is available. The Greywater Controller mounted on the Manifold automates the greywater system.

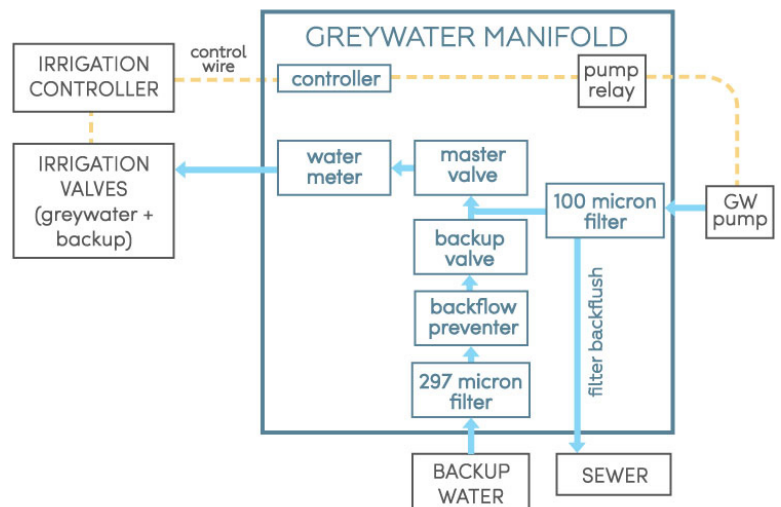

Manifold Details

Greywater Filter

Greywater is filtered through a 100 micron filter at the Manifold. The filter is automatically backflush based upon how many gallons has passed through the filter.

Backup Water Filter

Backup water is filtered through a 297 micron filter before distribution to the irrigation valves.

Backflow Prevention

A backflow preventer (reduced pressure principle device) is installed on the backup water supply to prevent mixing between the greywater and backup water.

Backup Valve

If the greywater tank is empty, the Greywater Controller opens the backup valve to supply backup water to the irrigation valves when the irrigation controller is running. Backup water is also used to backflush the greywater filter.

Master Valve

A master valve is installed on the supply to the irrigation valves and shuts off all water to the irrigation valves when the irrigation controller is not running, and when certain flow alarms are present.

Water Meter

The water meter tracks both greywater and backup water use and displays the information on the Controller LCD screen. The flow rate of the irrigation system is also displayed on the LCD screen.

Greywater Manifold, wall-mounted

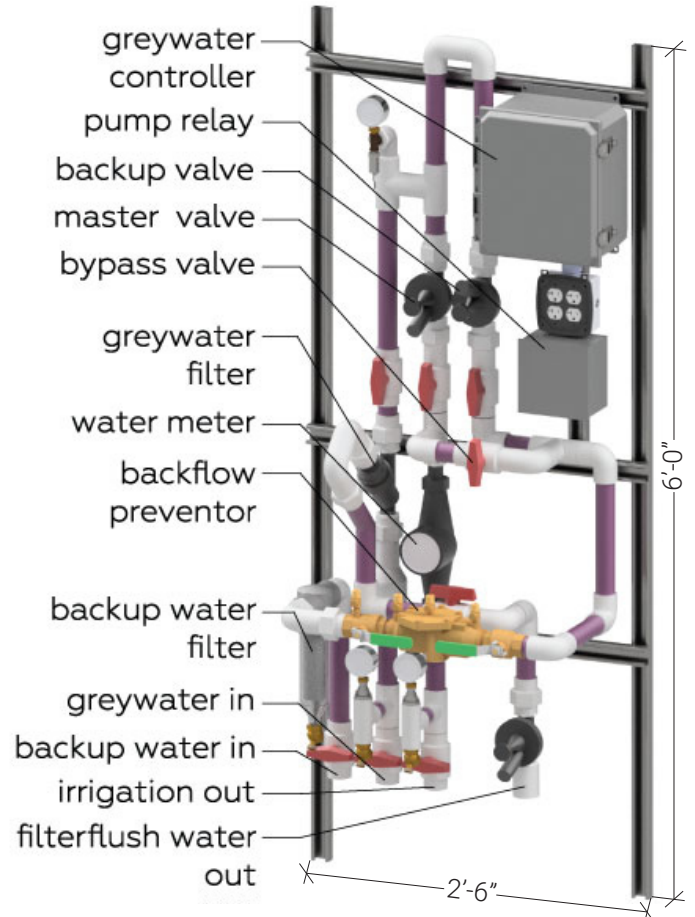

Technical Specifications

System Requirements:

Maximum Greywater Drain	
Size Fom Building:	3" pipe
Backup Water Supply:	1.25" pipe size, 60 PSI static min.
Electrical Supply:	120VAC 15 amp circuit
Maximum Drip Zone Size:	16 GPM
Maximum # of Zones:	unlimited

Materials:

Manifold Piping:	1.25" Sch.40 PVC
Greywater Tank:	Polyethylene plastic

Warranty:	One-year parts warranty
-----------	-------------------------

Performance:

Maximum Pressure Rating:	150 PSI
Supply to Irrigation:	16 GPM @ 45 PSI max.
Greywater Processed:	up to 320 gallons per day (8 ppl)
Tank Storage Capacity:	250 gallons
Greywater Filtration:	100 micron
Backup Water Filtration:	297 microns
Maintenance Interval:	once per year
CA Code Compliant:	yes

Electrical Load:

Pump:	½ HP, 120VAC@ 10 amps
Controller:	120VAC@ 1 amp